

Instrucciones de montaje

Assembly instructions



Te aconsejamos / We advise you

Ordena y cuenta las piezas y herrajes

Habilita una zona para el montaje

Utiliza la caja de embalaje desplegada como superficie de apoyo

No fuerces los tornillos y los elementos de montaje

Sigue paso a paso las instrucciones de montaje

Order and count the parts and fittings

Enable an area for assembling.



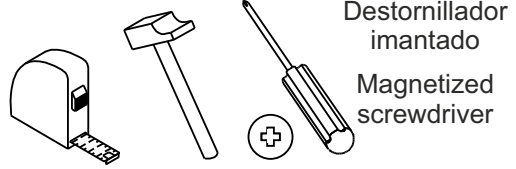

Do not force the screws or assembly parts

Follow the assembly instructions step by step

Herramientas necesarias Tools required

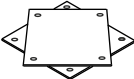
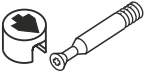

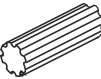
Herrajes incluidos / Fittings included

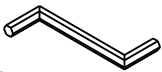
Rod x 2 Nº72130 	Exc x 38 Nº721016/721017 	Col x 1 Nº721060 	Rei x 16 Nº721020  0 1 2 3 4 5 cm
Tcp x 8 Nº721308 	Taco x 4 Nº721045 	Top x 4 Nº721074 	Lz x 1 Nº721034 

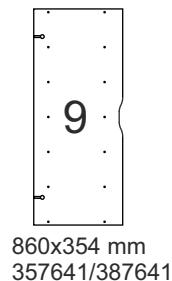
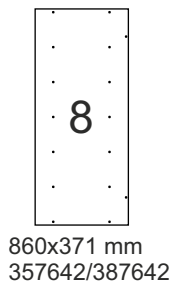
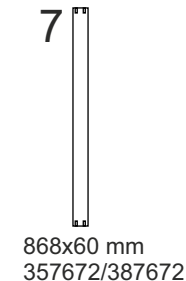
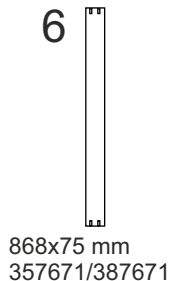
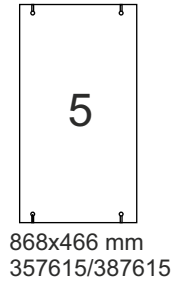
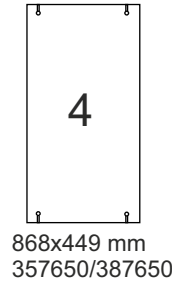
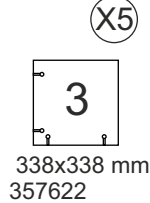
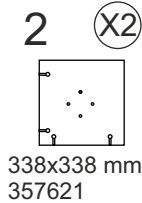
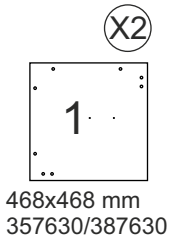

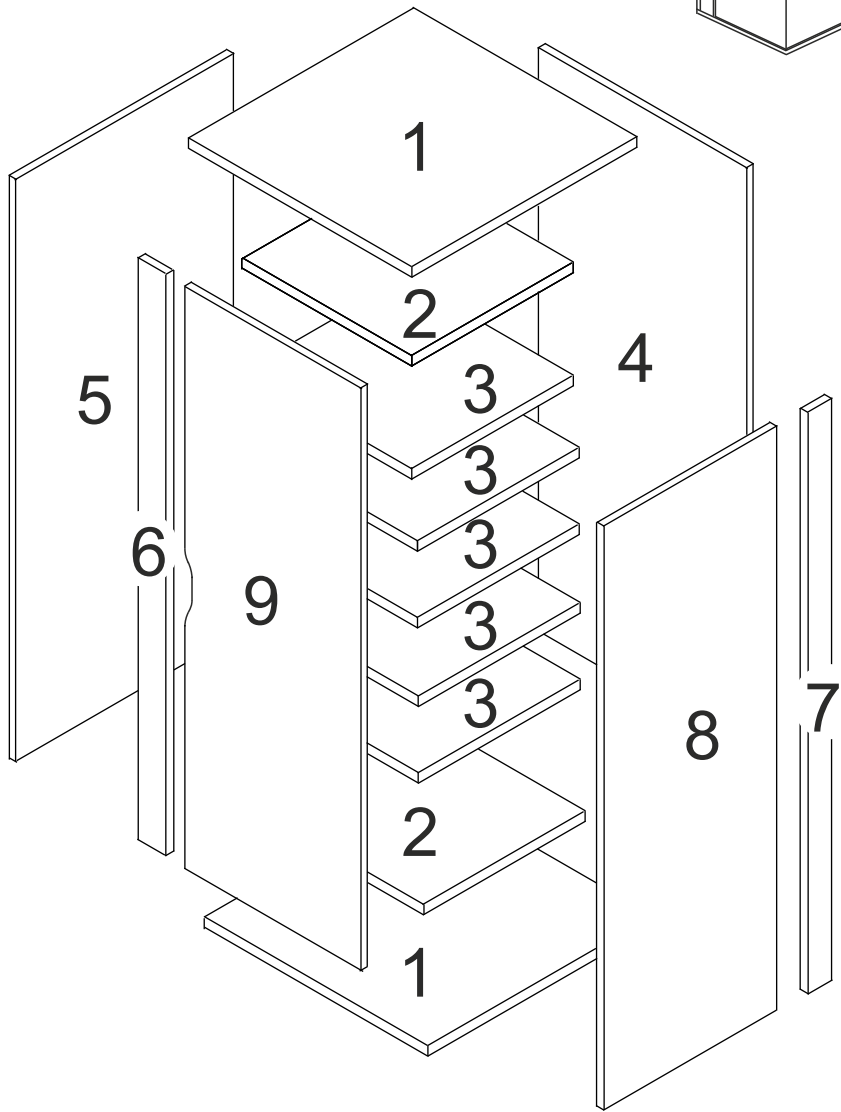
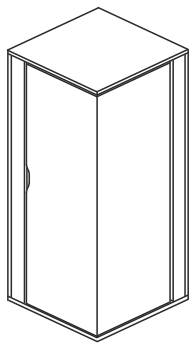

1

Exc x 4

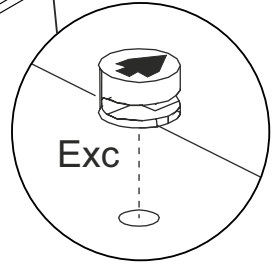
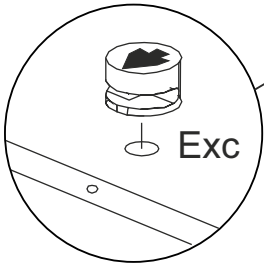
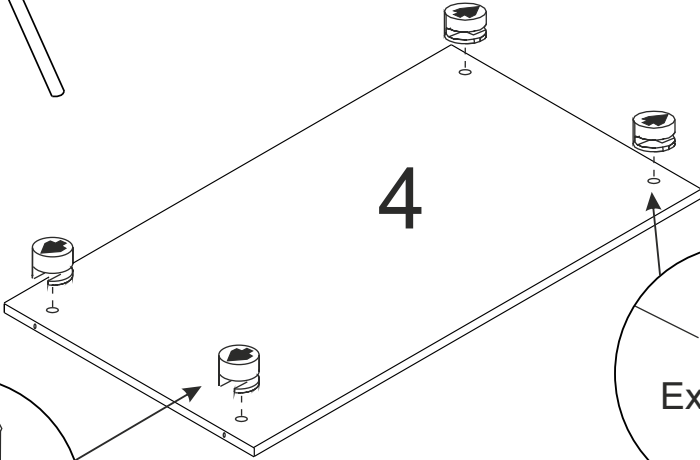
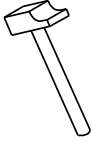

Exc x 4

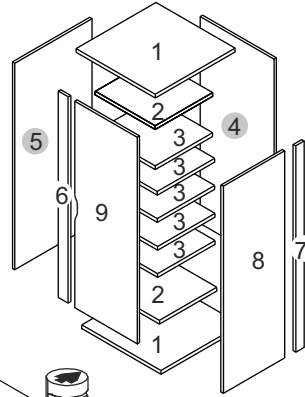
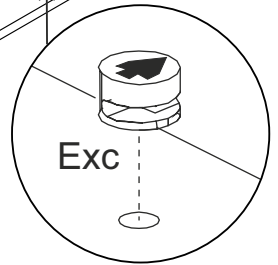
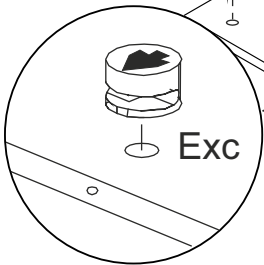
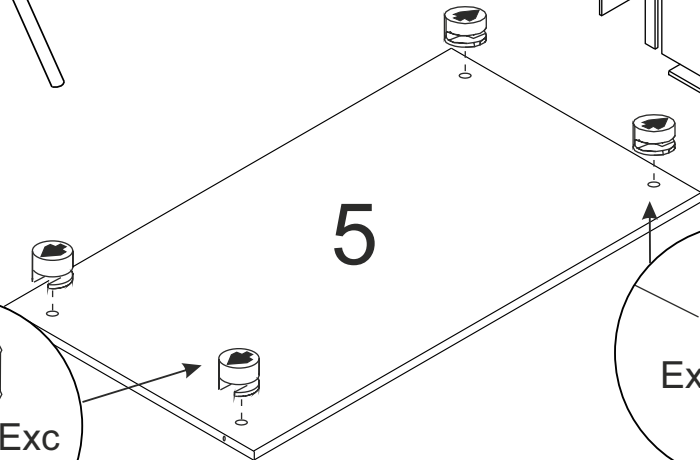
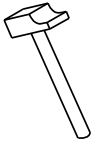

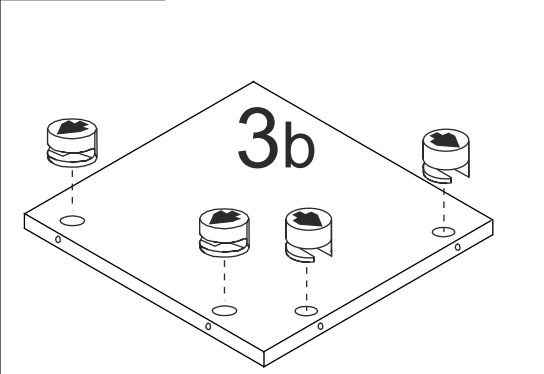
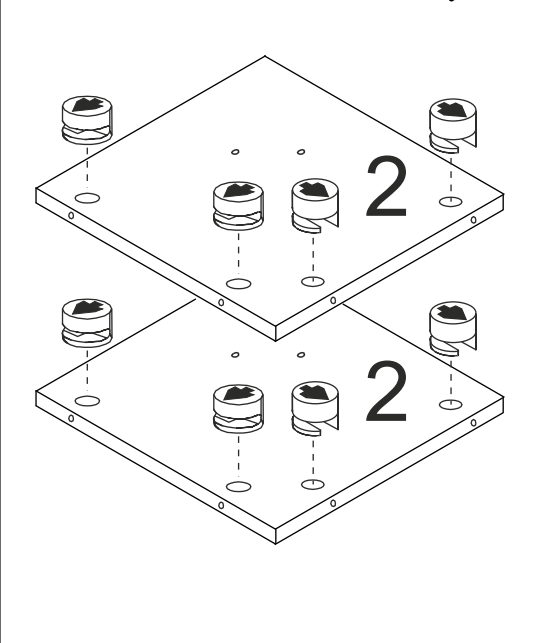
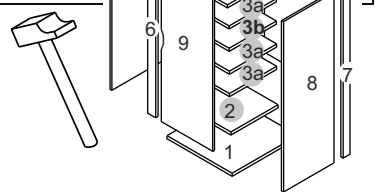
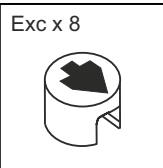
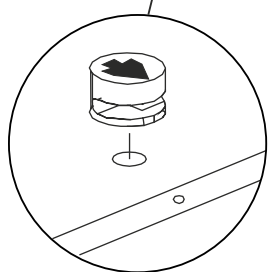
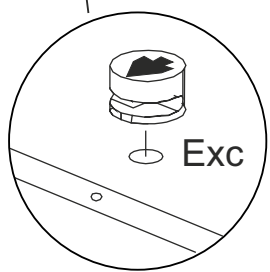
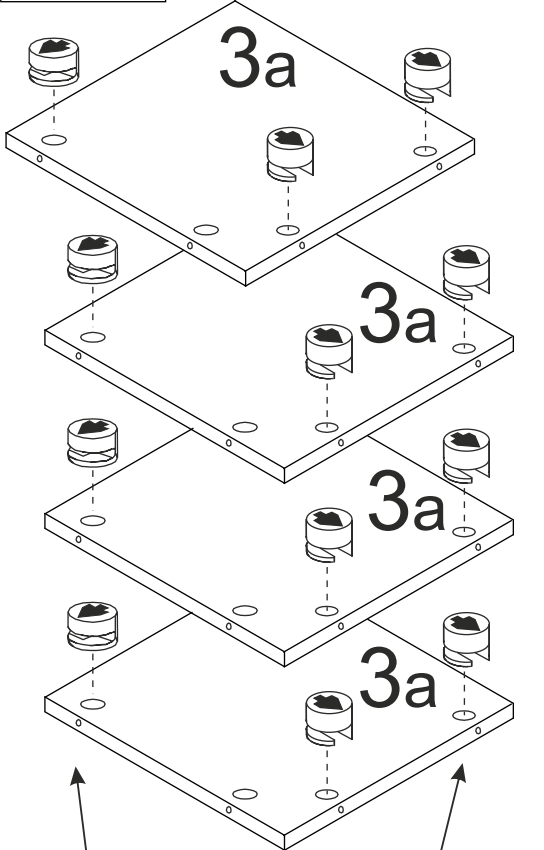
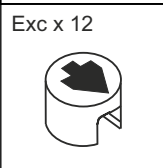

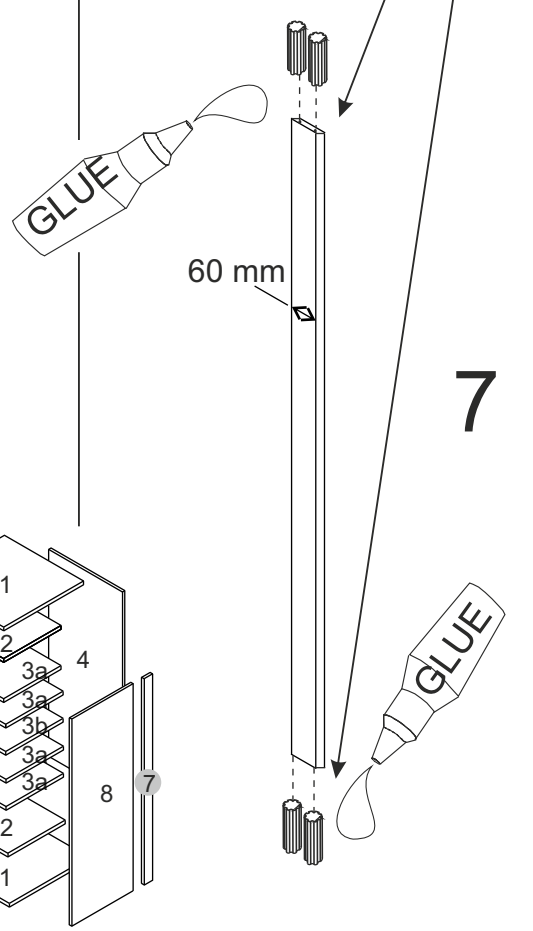
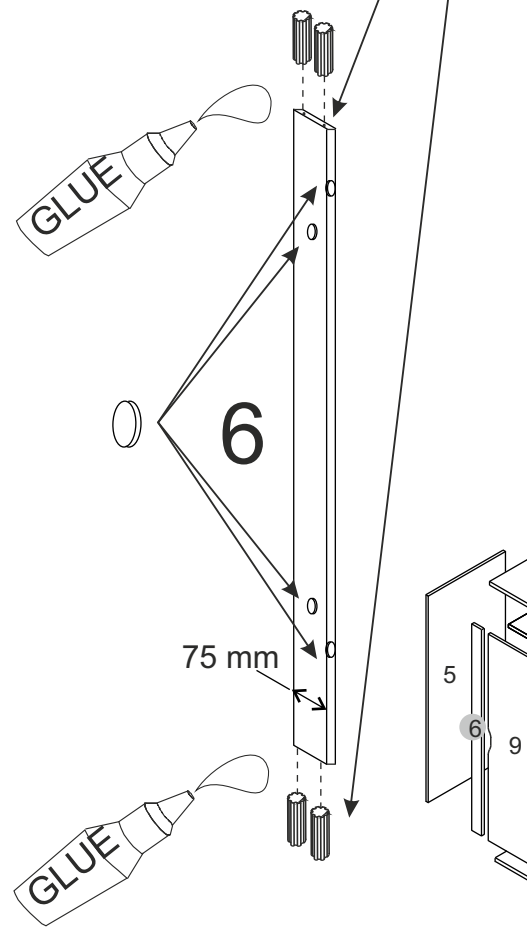
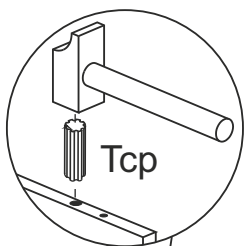
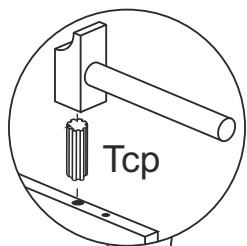
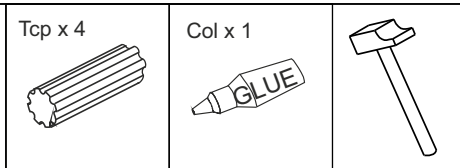
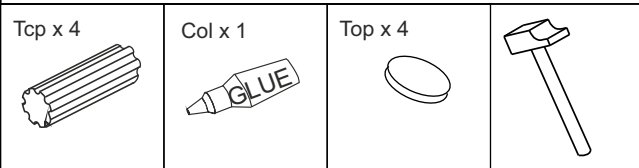

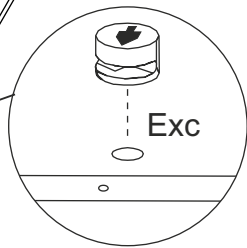
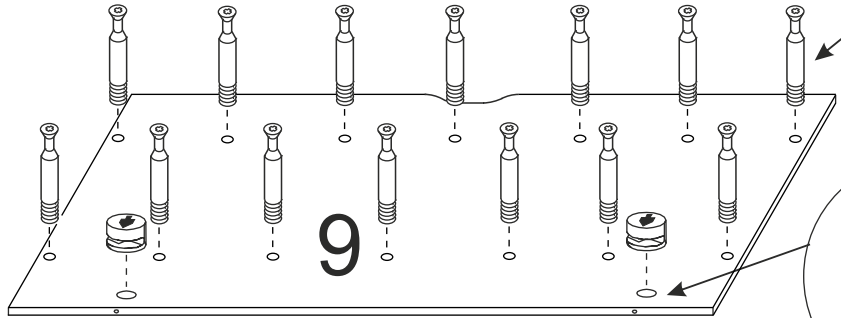
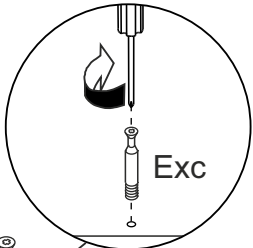
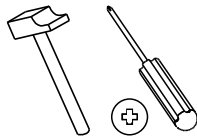
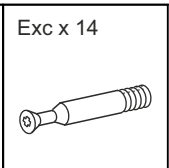
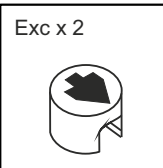
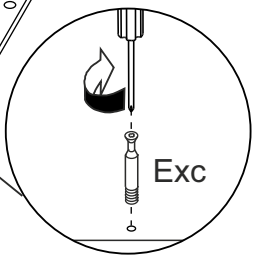
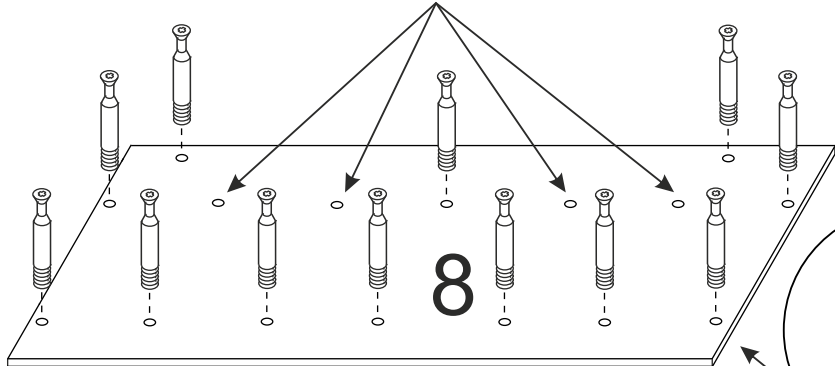
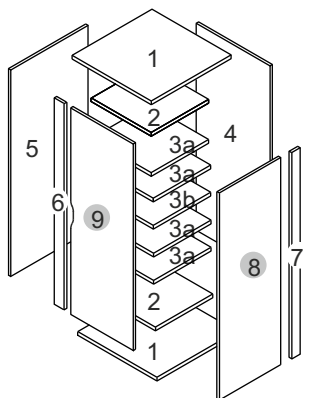
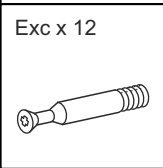

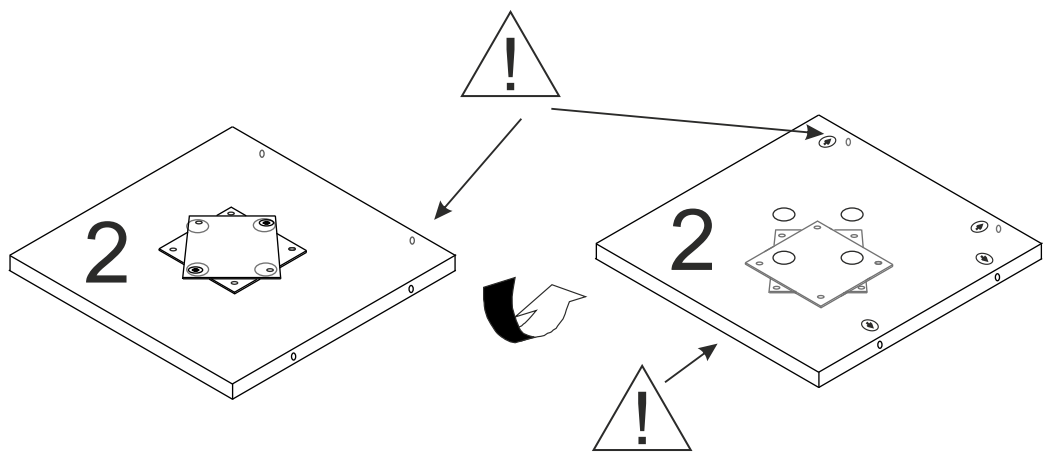
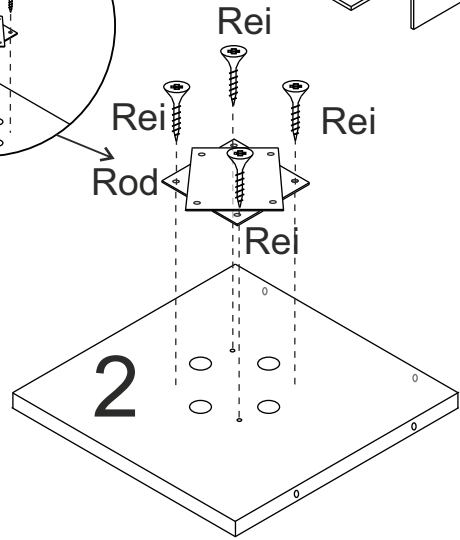
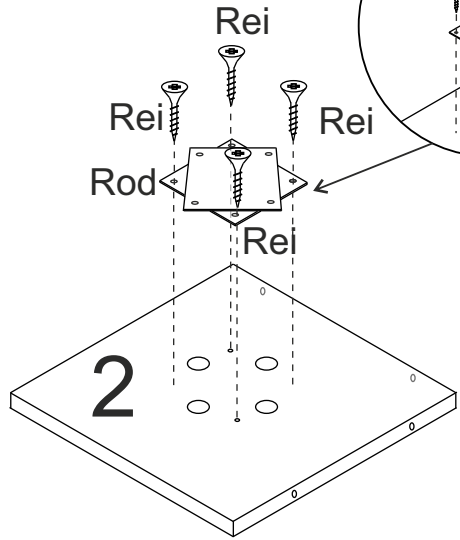
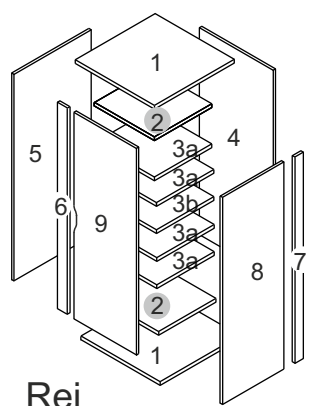
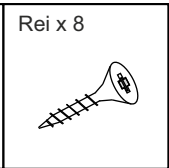
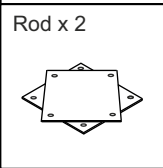

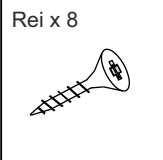

Destornillador Magnetized
imantado screwdriver

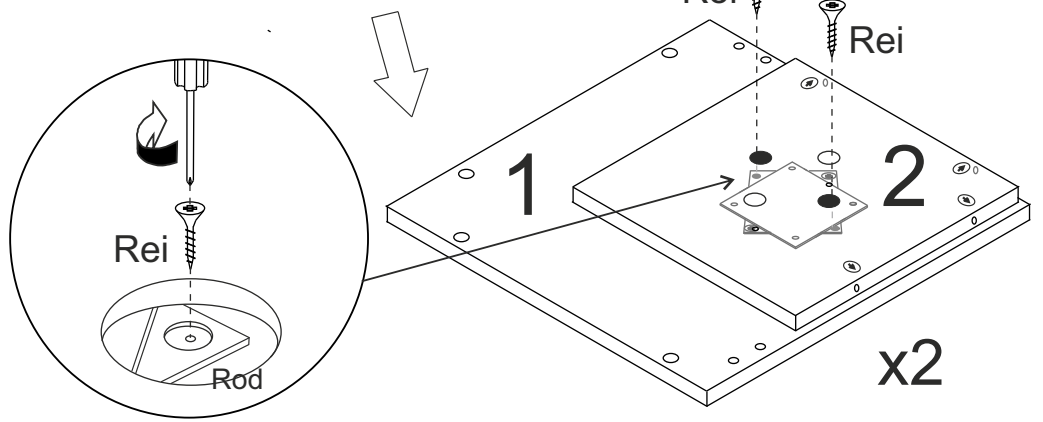
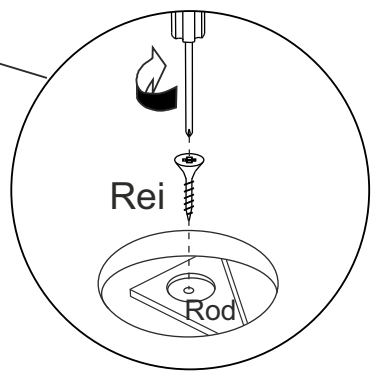
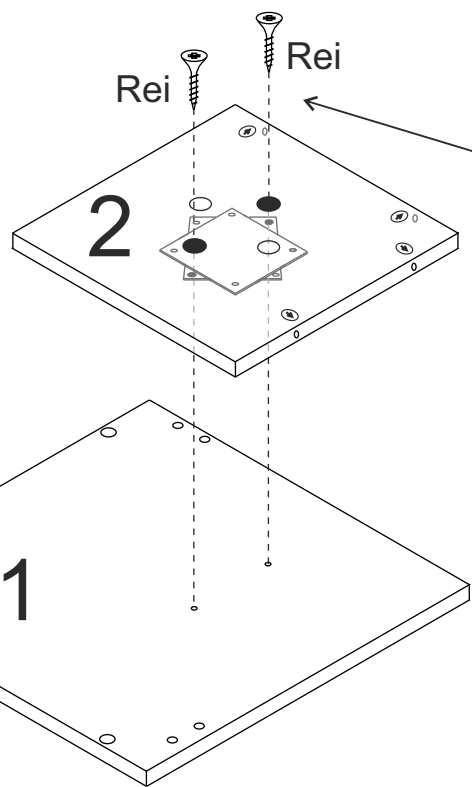
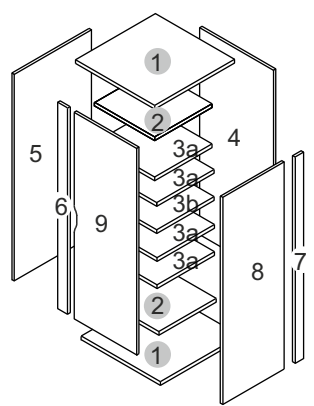

Exc x 8

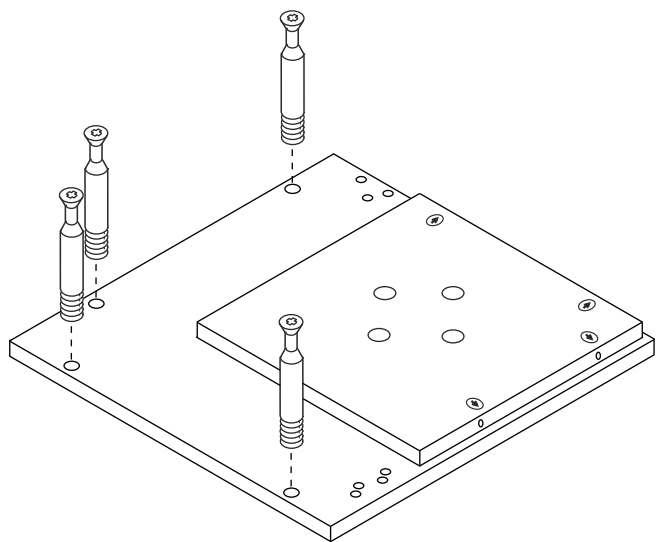
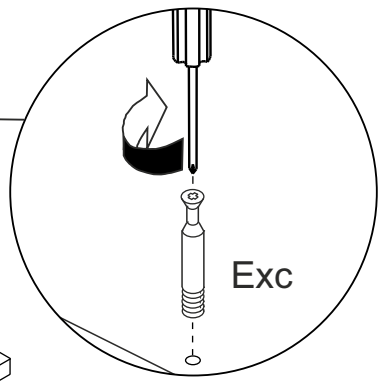
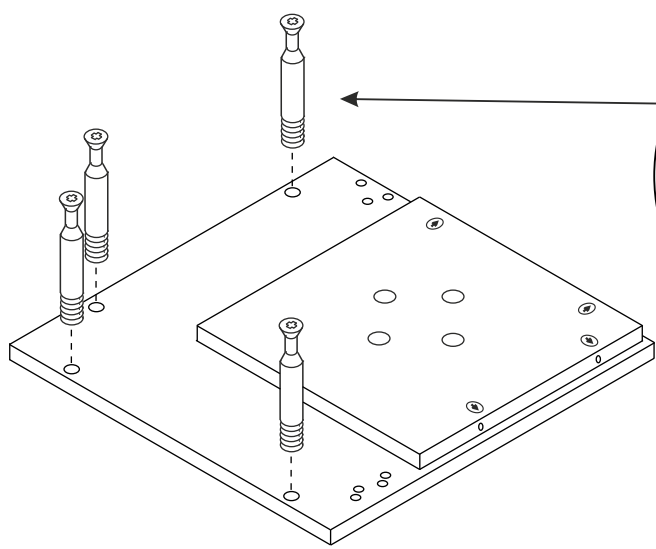
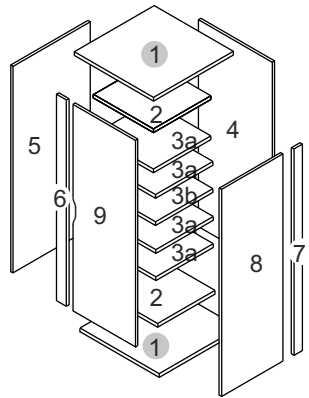

2

Tac x 4



Lz x 1

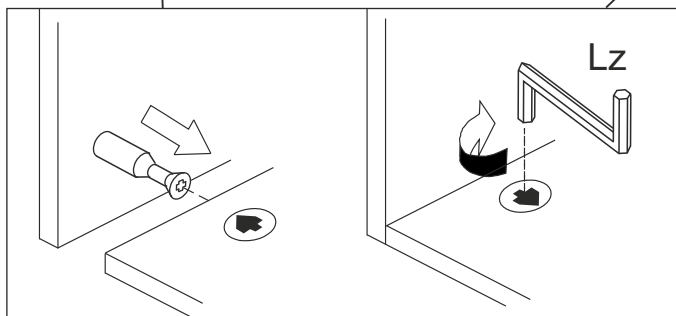
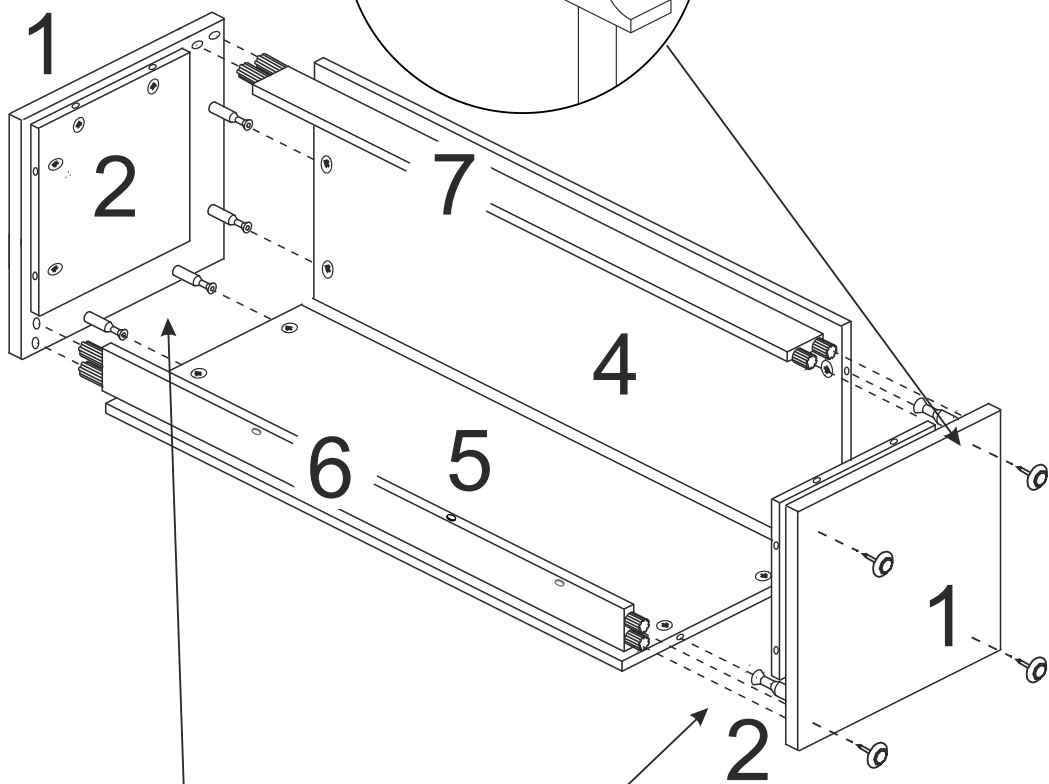
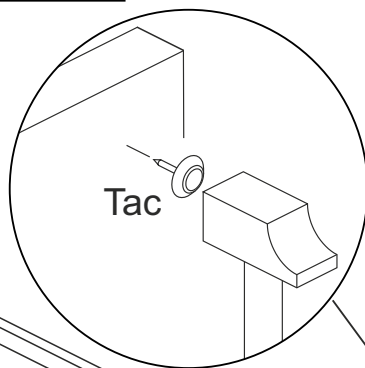
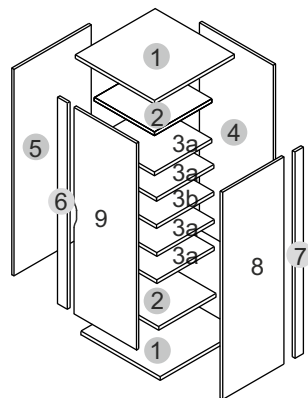
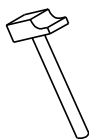

3

Lz x 1

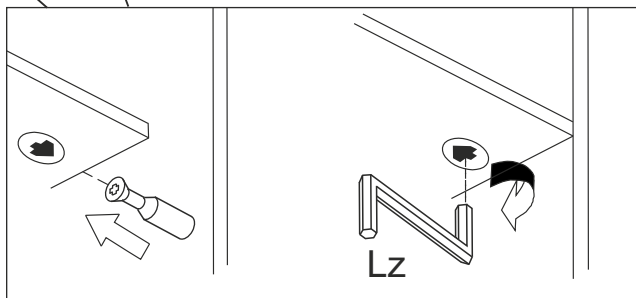
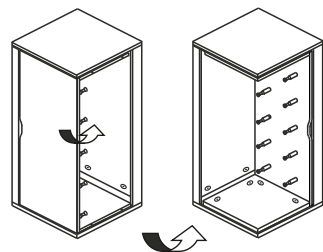
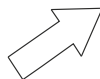
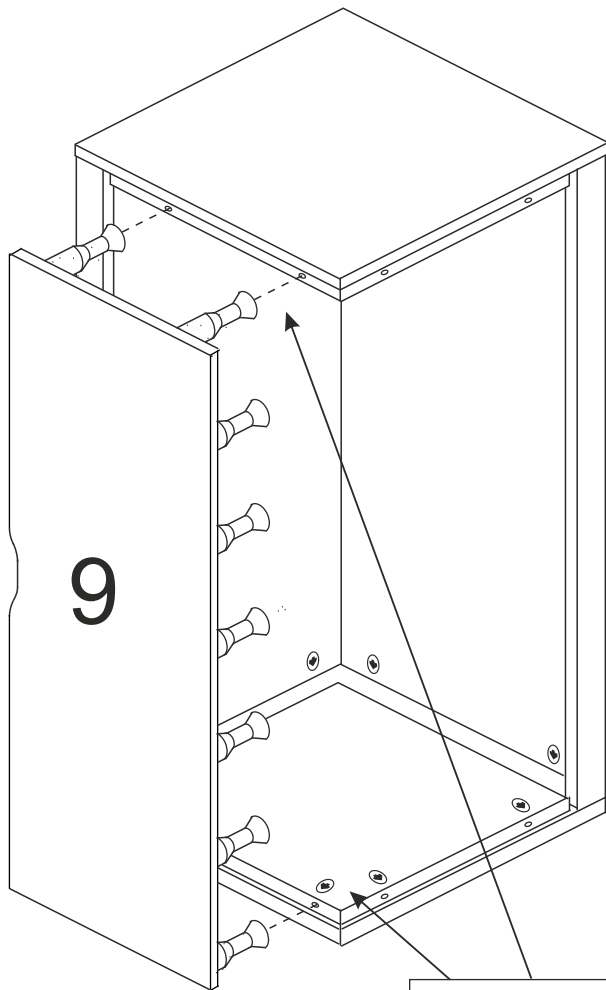
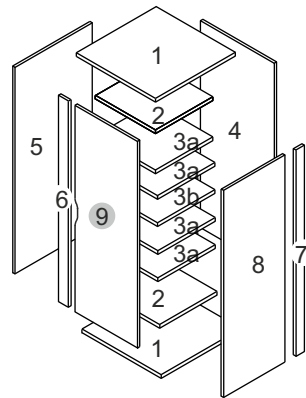
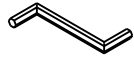

4

Lz x 1

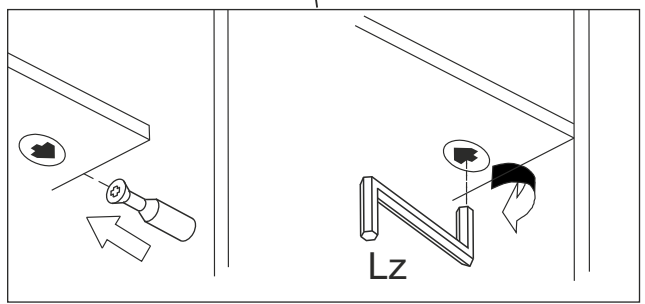
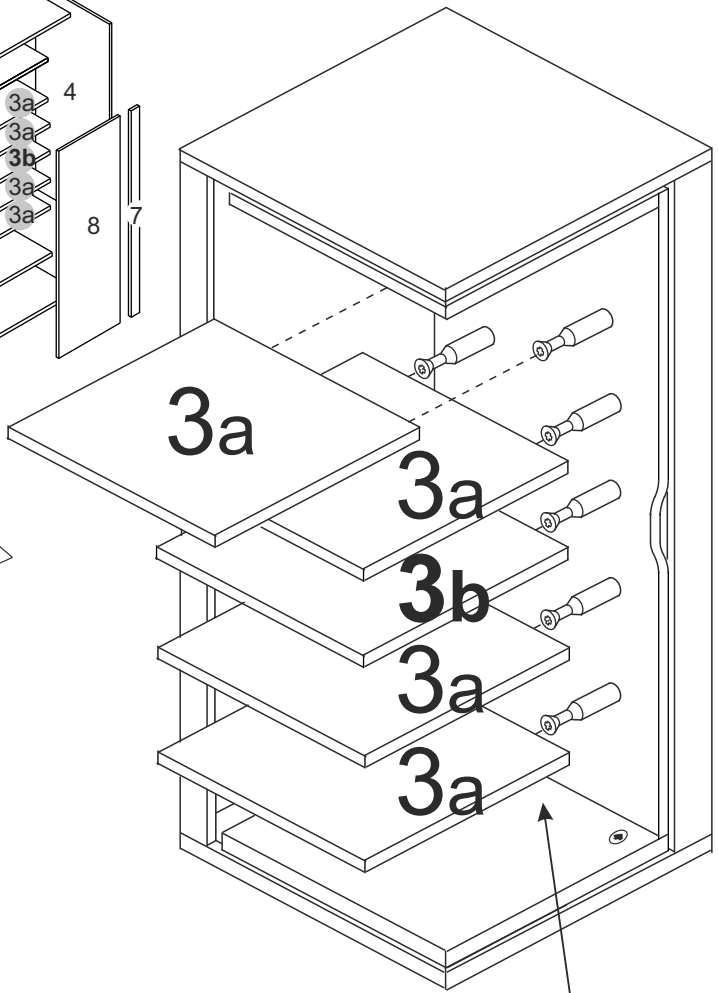
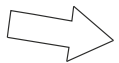
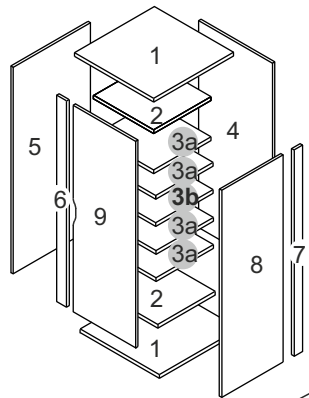
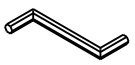

5

Lz x 1

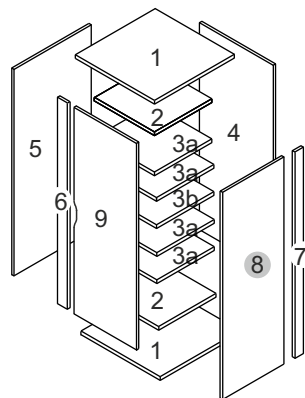
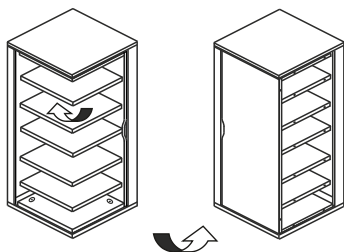
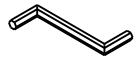

Giramos la parte giratoria

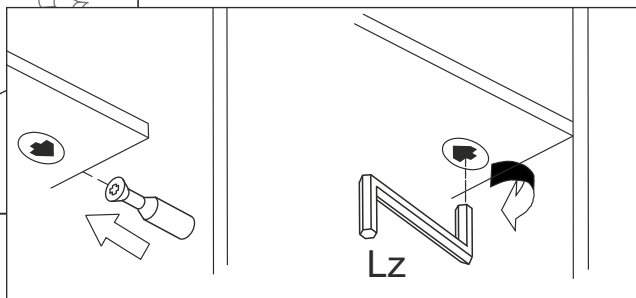
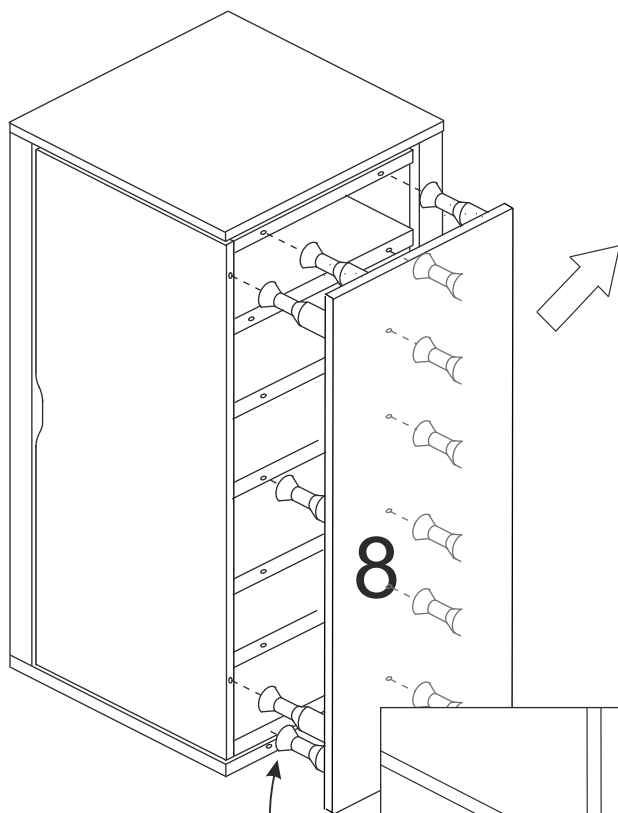

6

Lz x 1

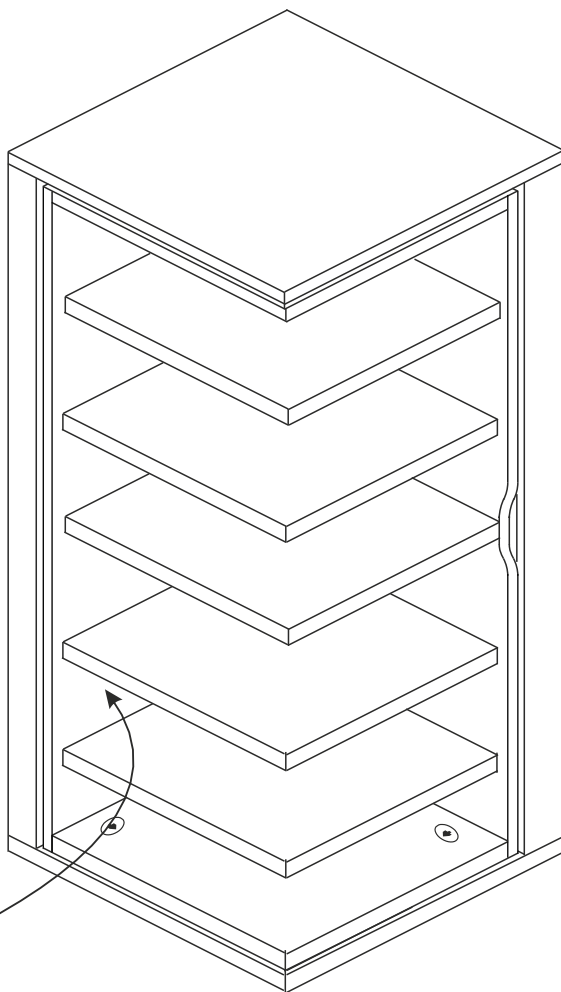

CONDICIONES DE USO Y MANTENIMIENTO

Producto de uso doméstico.

Evitar colocar el mueble cerca de fuentes de calor, de humedad o de una fuerte luz solar.

No lo limpie con productos abrasivos, ni disolventes.

Quitar el polvo antes de limpiarlo.

Utilizar un paño húmedo, limpio y sin pelos.

CONDITIONS OF USE AND MAINTENANCE OF FURNITURE

Product for domestic use only.

Avoid placing the furniture near sources of heat, damp, or strong sunlight.

Do not clean with abrasive products or cleaning products with solvents.

Use a dust remover before any cleaning process.

It is recommended to use a damp, lint-free clean cloth.

ATENCIÓN AL CLIENTE

CUSTOMER SUPPORT

(+34)964 321 111

8am-1pm 3pm-5:30pm lunes a viernes
Monday to Friday

Web: www.mueblespitarch.com

e-mail: comercial@mueblespitarch.com

LOTE/BATCH NUMBER

It is inside the Spanish assembly instructions